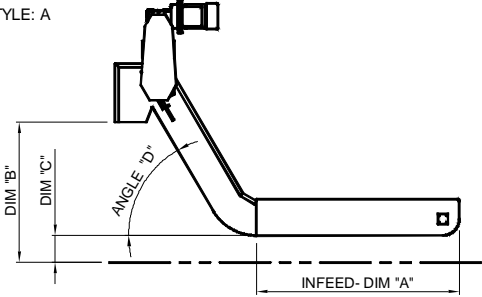
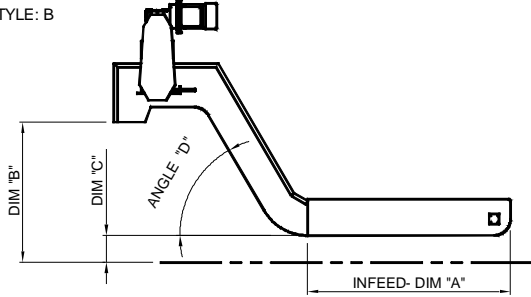
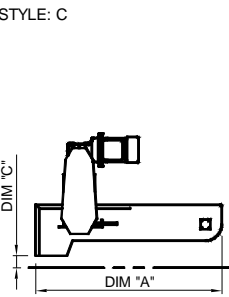
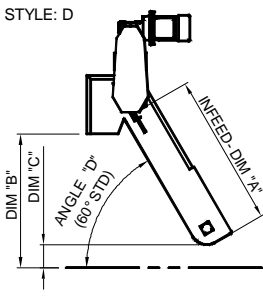
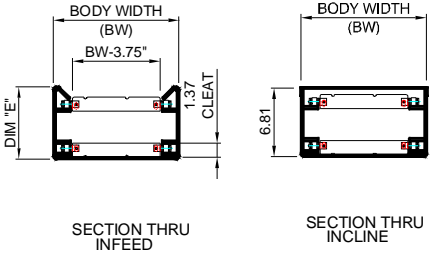

Dragout Conveyor Quote Sheet

Company Name _____ Contact Name _____

Address _____

Phone _____ Fax _____ Quote Quantity _____

<p>STYLE: A</p> 	<p>STYLE: B</p> 	<p><u>Conveyor Dimensions</u></p> <p>Style: _____</p> <p>Dim "A" _____</p> <p>Dim "B" _____</p> <p>Dim "C" _____</p> <p>Angle "D" _____ (45 & 60 degrees are standard.)</p> <p>Dim "E" _____</p> <p>Dim "F" _____</p> <p>Dim "G" _____</p>
<p>STYLE: C</p> 	<p>STYLE: D</p> 	
 <p>SECTION THRU INFEED SECTION THRU INCLINE</p>		
<p>Body Width: _____</p> <p>Cleat Centers _____ (1 3/8" high)</p> <p>Belt Speed:</p> <p><input type="checkbox"/> 5 FPM</p> <p><input type="checkbox"/> 7 FPM</p> <p><input type="checkbox"/> 10 FPM</p> <p><input type="checkbox"/> Other _____</p>	<p>Voltage:</p> <p><input type="checkbox"/> 110V (single ph.)</p> <p><input type="checkbox"/> 220V (3 ph.)</p> <p><input type="checkbox"/> 440V (3 ph.)</p> <p><input type="checkbox"/> 575V (3 ph.)</p> <p><input type="checkbox"/> Other _____</p> <p>Controls:</p> <p><input type="checkbox"/> Start/Stop-Variable Speed</p> <p><input type="checkbox"/> Start/Stop/Reverse-Variable Speed</p> <p><input type="checkbox"/> Emergency Stop</p> <p><input type="checkbox"/> Zero Speed Proximity Sensor</p> <p><input type="checkbox"/> None</p>	

Notes _____



MASTER CONVEYORS INC.
 1979 Settingington Drive, Kingsville, Ontario N9Y 2E5
Toll Free: 877-726-9990 519-325-1370 Fax: 519-325-1374
 Web: www.masterconveyors.com Email: sales@masterconveyors.com