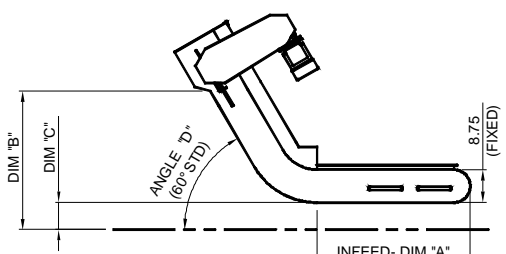
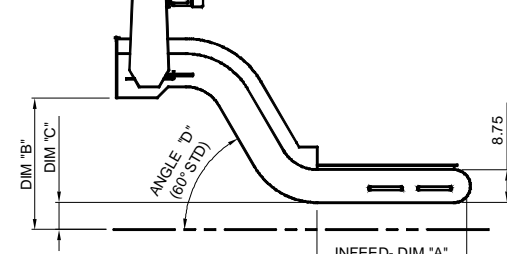
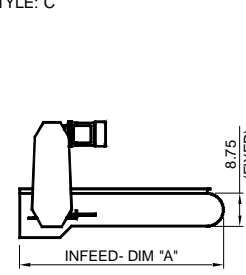
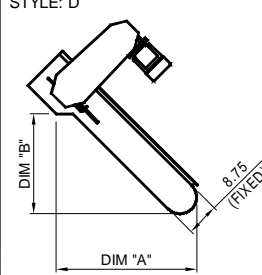
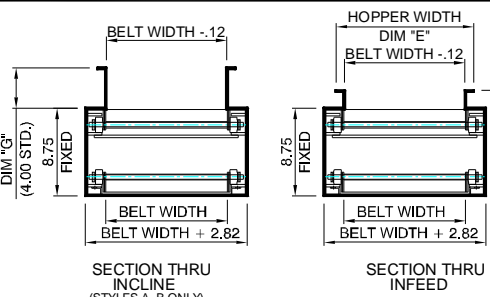

2.5" Pitch ChipMaster Quote Sheet

Company Name _____ Contact Name _____

Address _____

Phone _____ Fax _____ Quote Quantity _____

| | | |
|--|---|---|
| <p>STYLE: A</p>  | <p>STYLE: B</p>  | <p style="text-align: center;"><u>Conveyor Dimensions</u></p> <p>Style: _____</p> <p>Dim "A" _____</p> <p>Dim "B" _____</p> <p>Dim "C" _____</p> <p>Angle "D" _____ (45 & 60 degrees are standard.)</p> <p>Dim "E" _____</p> <p>Dim "F" _____</p> <p>Dim "G" _____</p> |
| <p>STYLE: C</p>  | <p>STYLE: D</p>  |  <p style="text-align: center;">SECTION THRU INCLINE (STYLES A, B ONLY)</p> <p style="text-align: center;">SECTION THRU INFEED</p> |
| <p>Belt Width: _____</p> <p><input type="checkbox"/> Plain</p> <p><input type="checkbox"/> Perforated</p> <p><input type="checkbox"/> Pimpled</p> <p><input type="checkbox"/> Perforated/Pimpled</p> <p><input type="checkbox"/> Impact Bars</p> <p>Cleat Centers _____ (1 1/2" high)</p> <p>Belt Speed:</p> <p><input type="checkbox"/> 12 FPM</p> <p><input type="checkbox"/> 15 FPM</p> <p><input type="checkbox"/> 20 FPM</p> <p><input type="checkbox"/> 30 FPM</p> <p><input type="checkbox"/> Other _____</p> | <p>Voltage:</p> <p><input type="checkbox"/> 110V (single ph.)</p> <p><input type="checkbox"/> 220V (3 ph.)</p> <p><input type="checkbox"/> 440V (3 ph.)</p> <p><input type="checkbox"/> 575V (3 ph.)</p> <p><input type="checkbox"/> Other _____</p> <p>Controls:</p> <p><input type="checkbox"/> Start/Stop-Variable Speed</p> <p><input type="checkbox"/> Start/Stop/Reverse-Variable Speed</p> <p><input type="checkbox"/> Emergency Stop</p> <p><input type="checkbox"/> Zero Speed Proximity Sensor</p> <p><input type="checkbox"/> None</p> | <p style="text-align: right;"><u>Material:</u></p> <p>Material to be Conveyed _____ Size: _____</p> <p>Lbs/Hr _____ Liquids Present _____ Type: _____</p> <p>GPM: _____ Hours of operation per day _____</p> <p><u>Features:</u></p> <p>• Heavy Duty Gearmotor • Friction Disk Torque Limiter • High Carbon Steel Tracks • Regreasable Bearings • 11 Gauge Formed Frame • Incline Cover w/ Chip Suppressor • Machine Enamel Paint, "Master Conveyors Blue" (or</p> <p><u>Options:</u></p> <p><input type="checkbox"/> Support Leg <input type="checkbox"/> Castors <input type="checkbox"/> Coolant Tank (capacity _____ Gal.)</p> <p><input type="checkbox"/> Filtration System <input type="checkbox"/> Side Mounted Gear-motor <input type="checkbox"/> Epoxy Paint (must provide specs.) For options not listed contact Master Conveyors Inc.</p> |

Notes _____



MASTER CONVEYORS INC.
 1979 Settingington Drive, Kingsville, Ontario N9Y 2E5
Toll Free: 877-726-9990 519-325-1370 Fax: 519-325-1374
 Web: www.masterconveyors.com Email: sales@masterconveyors.com